

### SMD ▪ Low Power LED 67-21S/R1C-D1530D1D21925Z2/2T



#### Features

- PLCC-2 package
- Top view Red LED
- Wide viewing angle
- Pb-free
- RoHS compliant

#### Description

The Everlight 67-21S package has high efficacy, low power consumption, wide viewing angle and a compact form factor. These features make this package an ideal LED for all lighting applications.

#### Applications

- Decorative and Entertainment Lighting
- Agriculture Lighting
- General use

## Device Selection Guide

Chip Materials	Emitted Color	Resin Color
AlGaInP	Red	Water Clear

## Absolute Maximum Ratings (T<sub>Soldering</sub>=25°C)

Parameter	Symbol	Rating	Unit
Forward Current	I <sub>F</sub>	20	mA
Peak Forward Current (Duty 1/10 @10ms)	I <sub>FP</sub>	40	mA
Power Dissipation	P <sub>d</sub>	50	mW
Operating Temperature	T <sub>opr</sub>	-40 ~ +85	°C
Storage Temperature	T <sub>stg</sub>	-40 ~ +100	°C
Thermal Resistance (Junction / Soldering point)	R <sub>th J-S</sub>	50	°C/W
Junction Temperature	T <sub>j</sub>	115	°C
Soldering Temperature	T <sub>sol</sub>	Reflow Soldering : 260 °C for 10 sec. Hand Soldering : 350 °C for 3 sec.	

Note:

The products are sensitive to static electricity and must be carefully taken when handling products

## Electro-Optical Characteristics (T<sub>Soldering</sub>=25°C)

Parameter	Symbol	Min.	Typ.	Max.	Unit	Condition
Luminous flux <sub>(1)</sub>	∅	0.5	-----	1.5	lm	I <sub>F</sub> =20mA
Forward Voltage	V <sub>F</sub>	1.9	-----	2.5	V	I <sub>F</sub> =20mA
Viewing Angle	2θ <sub>1/2</sub>	-----	120	-----	deg	I <sub>F</sub> =20mA
Reverse Current	IR	-----	-----	50	μA	V <sub>R</sub> =5V

Notes:

1. Tolerance of Radiometric Luminous flux: ±11%.
2. Tolerance of Forward Voltage: ±0.1V.

### Bin Range of Photometric

Bin Code	Min.	Max.	Unit	Condition
D1	0.5	1.0	lm	I <sub>F</sub> =20mA
D2	1.0	1.5		

Notes:  
 Tolerance of Luminous flux: ±11%

### Bin Range of Forward Voltage

Bin Code	Min.	Max.	Unit	Condition
19B	1.9	2.1	V	I <sub>F</sub> =20mA
21B	2.1	2.3		
23B	2.3	2.5		

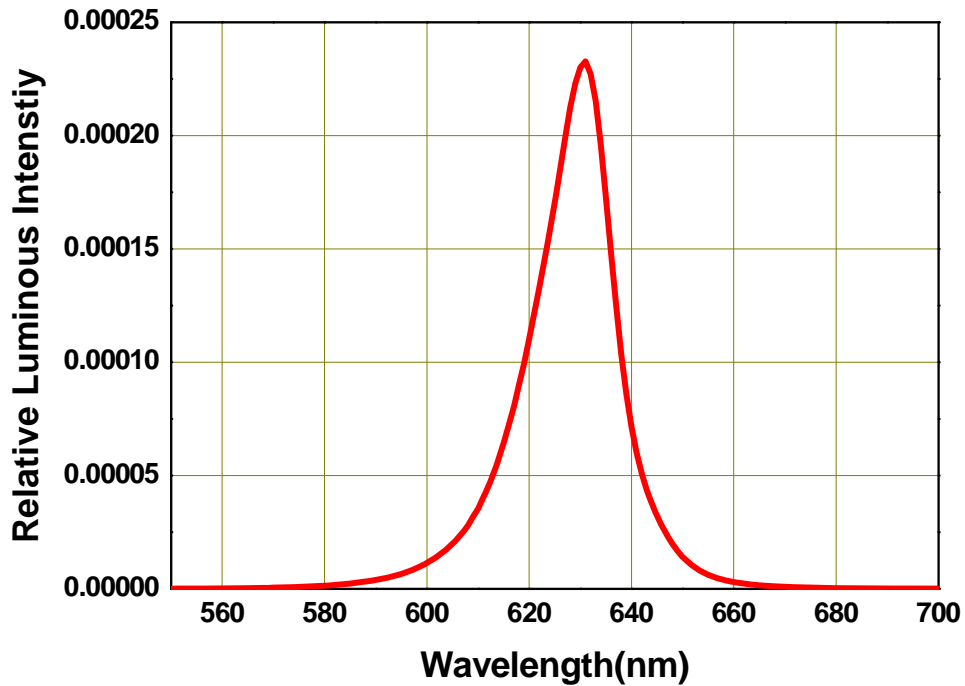
Note:  
 Tolerance of Forward Voltage: ±0.1V.

### Dominant Wavelength Bins

Bin Code	Min.	Max.	Unit	Condition
O54	615	620	nm	I <sub>F</sub> =20mA
R51	620	625		
R52	625	630		

Notes:  
 Dominant / Peak wavelength measurement tolerance: ±1nm.

### Spectrum Distribution



### Typical Electro-Optical Characteristics Curves

Fig.1 – Forward Voltage Shift vs. Junction Temperature

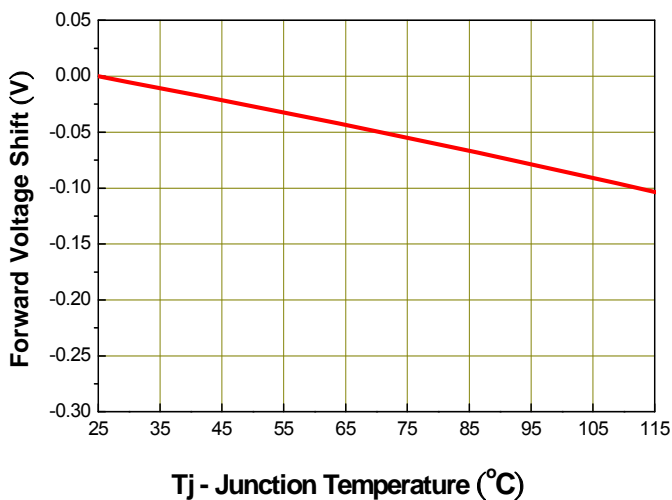
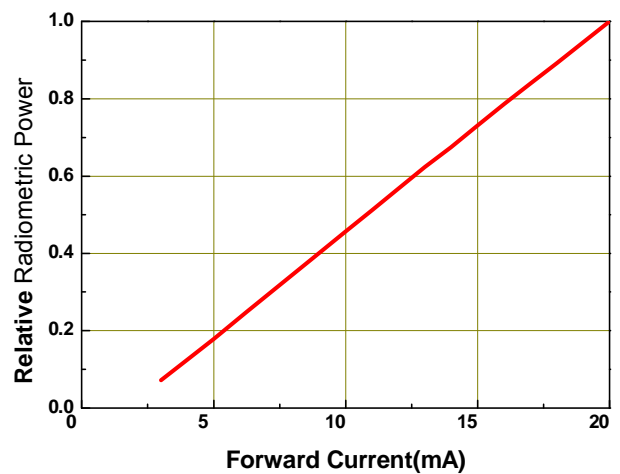
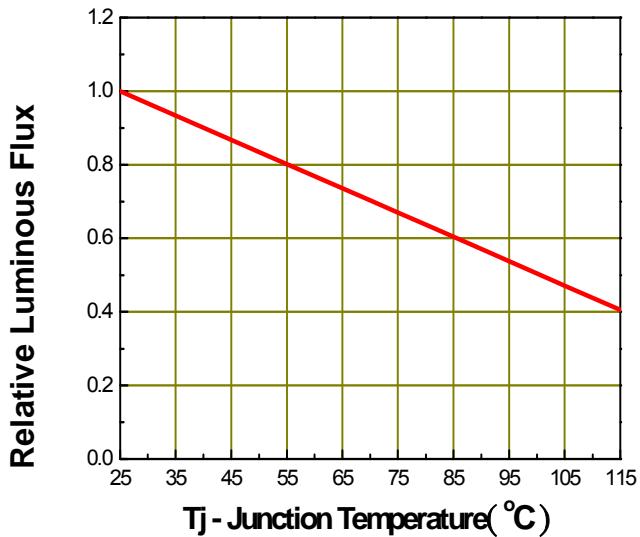


Fig.2 - Relative Radiometric Power vs. Forward Current

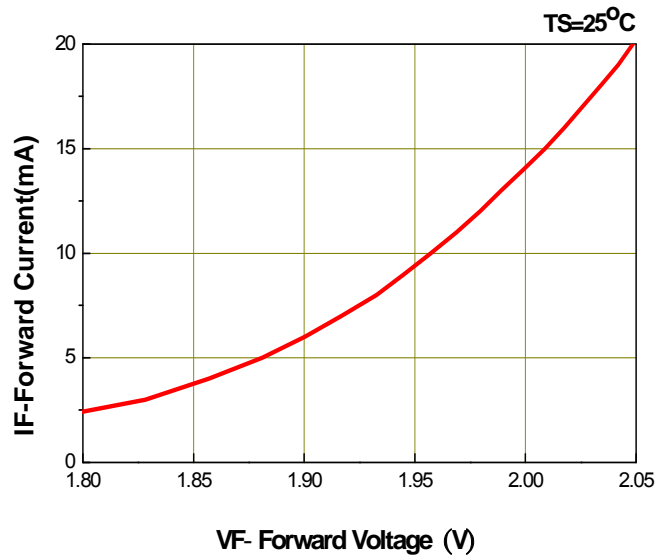


**Typical Electro-Optical Characteristics Curves**

**Fig.3 - Relative Luminous Intensity vs. Junction Temperature**

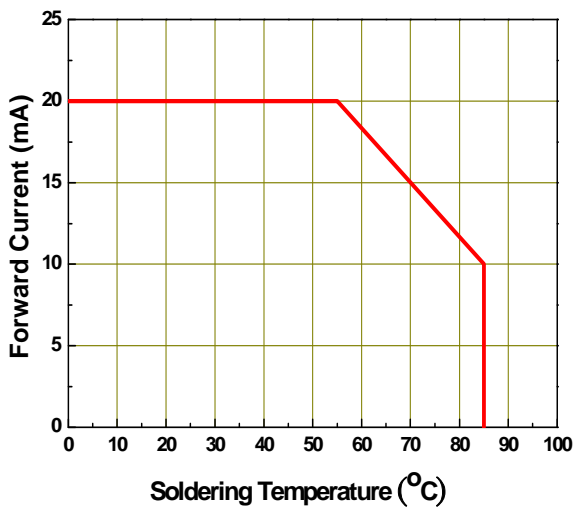


**Fig.4 - Forward Current vs. Forward Voltage**

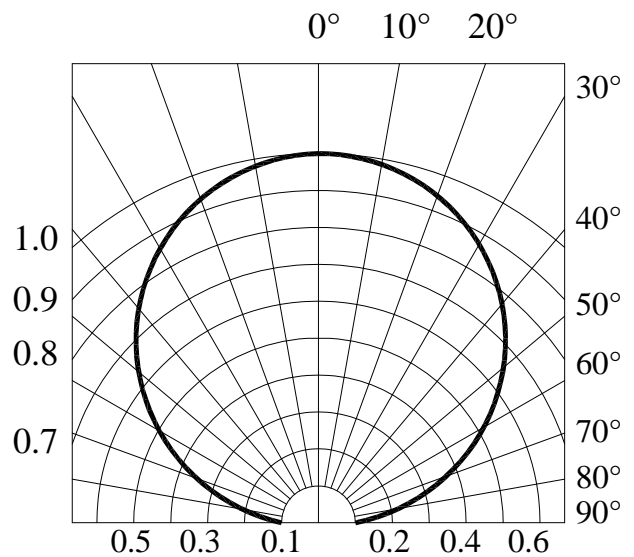


**Fig.5 – Max. Driving Forward Current vs. Soldering Temperature**

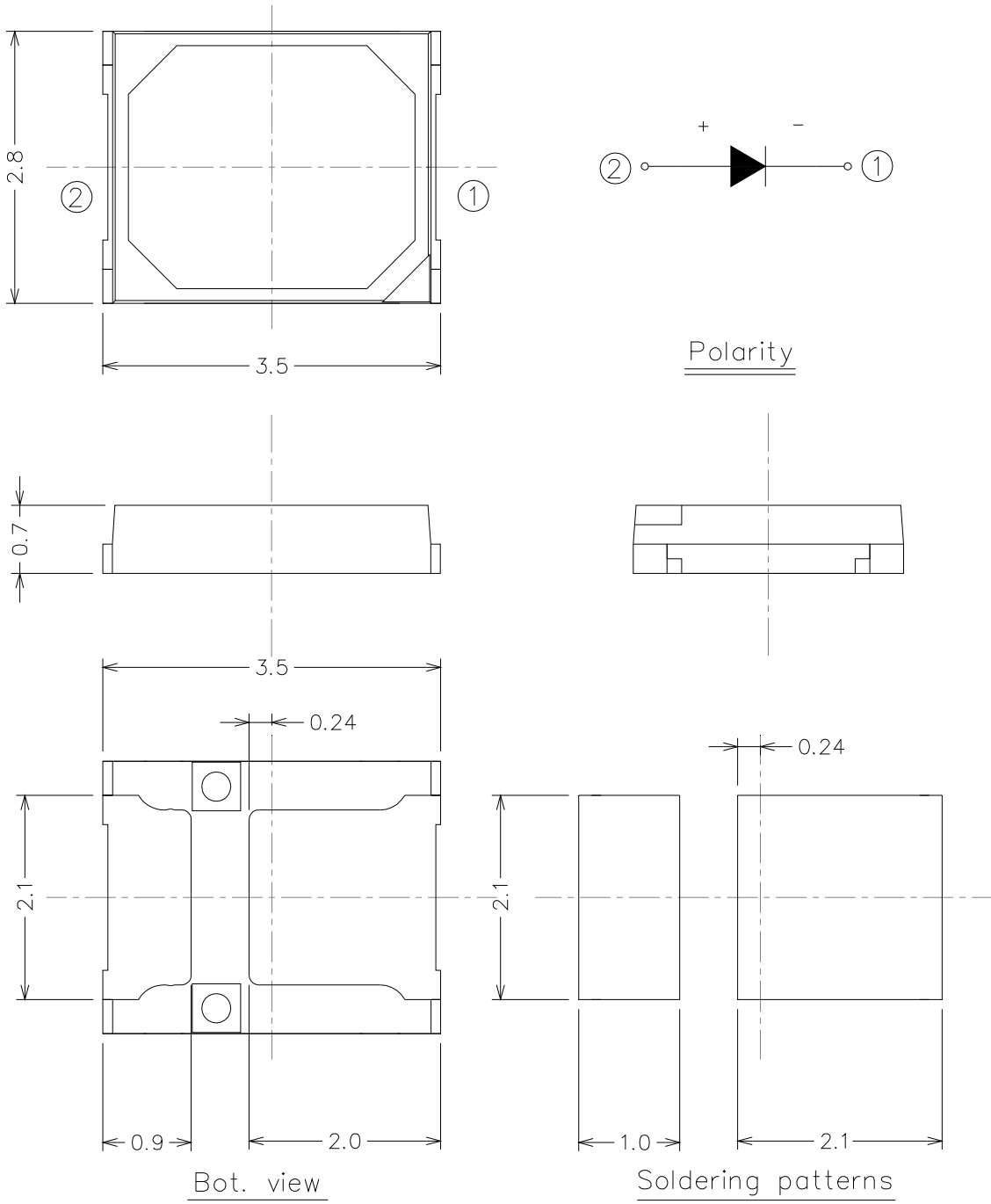
Rth j-s=50 ° C/W



**Fig.6 – Radiation Diagram**



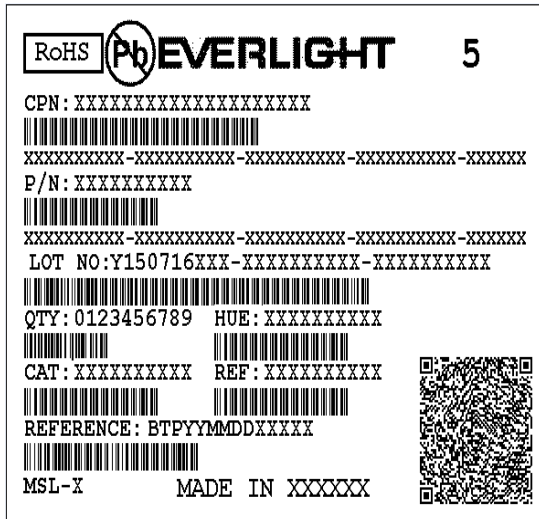
### Package Dimension



Note:  
Tolerance unless mentioned is  $\pm 0.15$  mm; Unit = mm

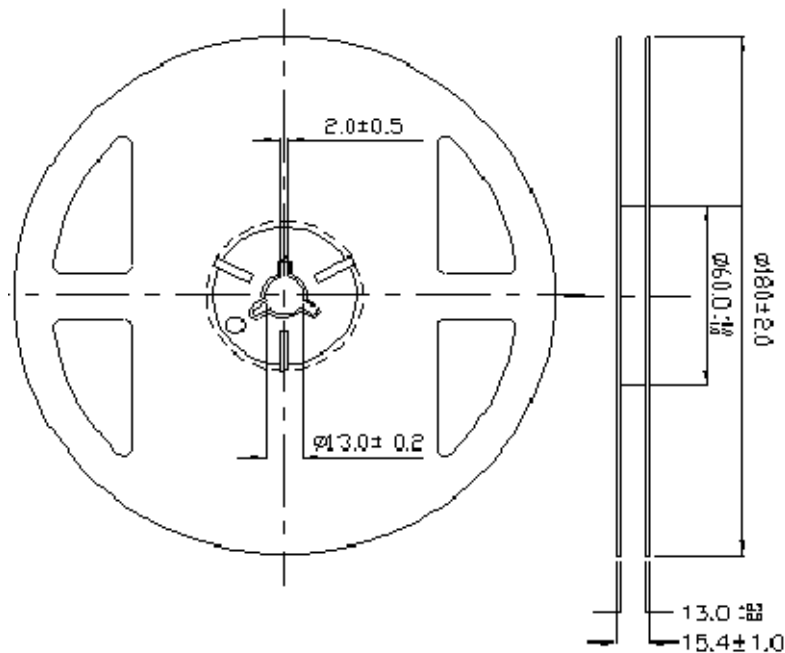
**Moisture Resistant Packing Materials**

**Label Explanation**



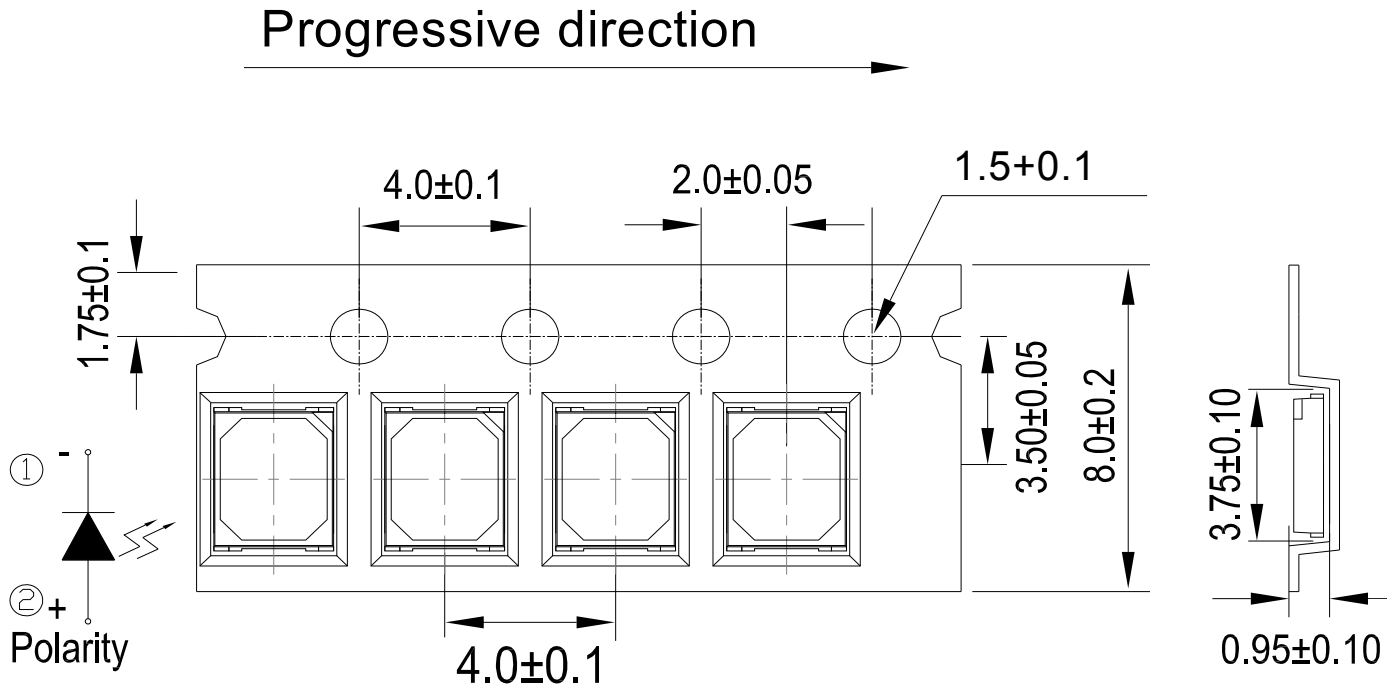
- CPN: Customer's Product Number
- P/N: Product Number
- QTY: Packing Quantity
- CAT: Luminous Intensity Rank
- HUE: Dom. Wavelength Rank
- REF: Forward Voltage Rank
- LOT No: Lot Number

**Reel Dimensions**



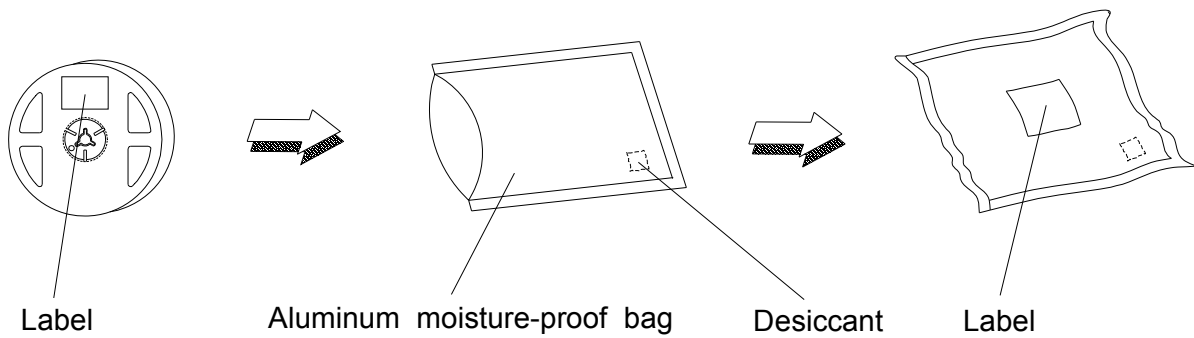
Note:  
 Tolerances unless mentioned  $\pm 0.1$ mm. Unit = mm

Carrier Tape Dimensions: Loaded Quantity 250/500/1000/2000/3000/4000 pcs. Per Reel



Note:  
Tolerance unless mentioned is  $\pm 0.1$ mm; Unit = mm

### Moisture Resistant Packing Process





## Reliability Test Items and Conditions

The reliability of products shall be satisfied with items listed below.

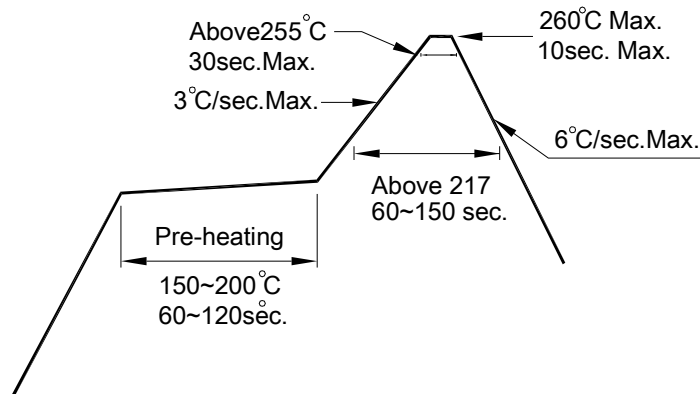
Confidence level : 90%

LTPD : 10%

No.	Items	Test Condition	Test Hours/Cycles	Sample Size	Ac/Re
1	Reflow Soldering	Temp. : 260°C/10sec.	6 Min.	22 PCS.	0/1
2	Thermal Shock	H : +100°C 20min $\int$ 10 sec L : -10°C 20min	200 Cycles	22 PCS.	0/1
3	Temperature Cycle	H : +100°C 30min $\int$ 5 min L : -40°C 30min	200 Cycles	22 PCS.	0/1
4	High Temperature/Humidity Storage	Ta=85°C,85%RH	1000 Hrs.	22 PCS.	0/1
5	High Temperature/Humidity Operation	Ta=85°C,85%RH, I <sub>F</sub> = 10mA	1000 Hrs.	22 PCS.	0/1
6	Low Temperature Storage	Ta=-40°C	1000 Hrs.	22 PCS.	0/1
7	High Temperature Storage	Ta=85°C	1000 Hrs.	22 PCS.	0/1
8	Low Temperature Operation Life	Ta=-40°C, I <sub>F</sub> = 20 mA	1000 Hrs.	22 PCS.	0/1
9	High Temperature Operation/ Life#1	Ta=25°C, I <sub>F</sub> = 20 mA	1000 Hrs.	22 PCS.	0/1
10	High Temperature Operation/ Life#2	Ta=55°C, I <sub>F</sub> =20mA	1000 Hrs.	22 PCS.	0/1
11	High Temperature Operation/ Life#3	Ta=85°C, I <sub>F</sub> = 10 mA	1000 Hrs.	22 PCS.	0/1

## Precautions for Use

1. Over-current-proof  
Customer must apply resistors for protection; otherwise slight voltage shift will cause big current change (Burn out will happen).
2. Storage
  - 2.1 Do not open moisture proof bag before the products are ready to use.
  - 2.2 Before opening the package: The LEDs should be kept at 30°C or less and 90%RH or less.
  - 2.3 After opening the package: The LED's floor life is 168 Hrs under 30°C or less and 60% RH or less. If unused LEDs remain, it should be stored in moisture proof packages.
  - 2.4 If the moisture absorbent material (silica gel) has faded away or the LEDs have exceeded the storage time, baking treatment should be performed using the following conditions.  
Baking treatment: 60±5°C for 24 hours.
3. Soldering Condition
  - 3.1 Pb-free solder temperature profile



- 3.2 Reflow soldering should not be done more than two times.
- 3.3 When soldering, do not put stress on the LEDs during heating.
- 3.4 After soldering, do not warp the circuit board.
4. Soldering Iron  
Each terminal is to go to the tip of soldering iron temperature less than 350°C for 3 seconds within once in less than the soldering iron capacity 25W. Leave two seconds and more intervals, and do soldering of each terminal. Be careful because the damage of the product is often started at the time of the hand solder.
5. Repairing  
Repair should not be done after the LEDs have been soldered. When repairing is unavoidable, a double-head soldering iron should be used (as below figure). It should be confirmed beforehand whether the characteristics of the LEDs will or will not be damaged by repairing.

