

## Side View LEDs (Height 0.4 mm)

### 99-218GLM2C/L5762SG6/TR8-T

#### Features

- Side view white LED
- White SMT package
- Lead frame package with individual 2 pins
- Wide viewing angle
- Soldering methods: IR reflow soldering
- Pb-free
- The product itself will remain within RoHS compliant version.



#### Descriptions

- Due to the package design, 99-218G has wide viewing angle, low power consumption and white LEDs are devices that are materialized by combing blue chips and special phosphor. This feature makes the LED ideal for light guide application.

#### Applications

- LCD Back Light
- Mobile Phones
- Indicators
- Illuminations
- Switch Lights

#### Device Selection Guide

Chip	Emitted Color	Resin Color
Material		
InGaN	Pure White	Water Clear

#### Coding

99-218GLM2C/LXX XX XX X/TR8-T

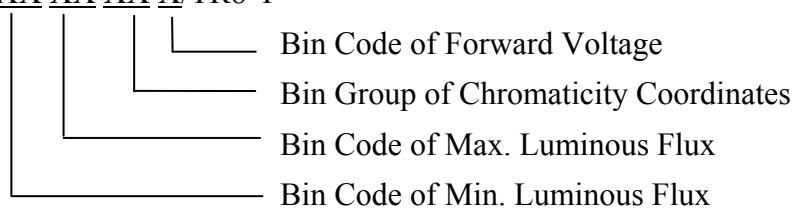

Side View LEDs (Height 0.4 mm)

99-218GLM2C/L5762SG6/TR8-T

Package Outline Dimensions

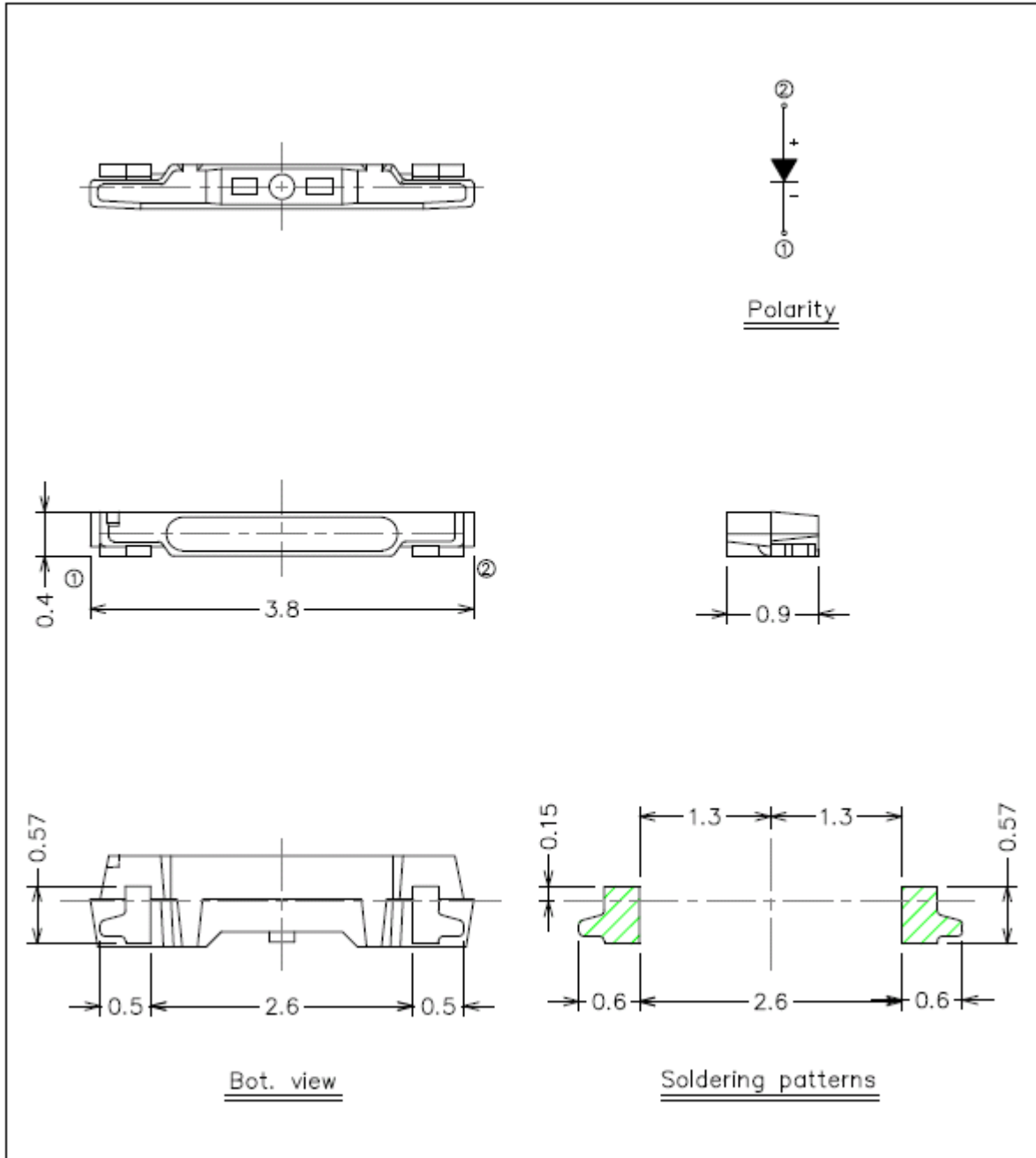

**Note:** The tolerances unless dimensions are  $\pm 0.1$ mm.

## Side View LEDs (Height 0.4 mm)

### 99-218GLM2C/L5762SG6/TR8-T

#### Absolute Maximum Ratings (Ta=25°C)

Parameter	Symbol	Rating	Unit
Reverse Voltage	V <sub>R</sub>	5	V
DC Forward Current	I <sub>F</sub>	30	mA
Pulse Forward Current (Duty 1/10 @1KHz)	I <sub>FP</sub>	100	mA
Power Dissipation	P <sub>d</sub>	110	mW
Operating Temperature	T <sub>opr</sub>	-40~ +85	°C
Storage Temperature	T <sub>stg</sub>	-40 ~ +90	°C
Soldering Temperature	T <sub>sol</sub>	Reflow Soldering: 260°C for 10sec. Hand Soldering: 350°C for 3sec.	

**Note:** The products are sensitive to static electricity and must be carefully taken when handling products.

#### Electro-Optical Characteristics (Ta=25°C)

Parameter	Symbol	Min.	Typ.	Max.	Unit	Condition
Luminous Flux	Φ	5.75	-----	6.5	lm	IF=20mA
Viewing Angle	2θ1/2	-----	120	-----	deg	
Forward Voltage	V <sub>F</sub>	2.95	-----	3.45	V	
Reverse Current	I <sub>R</sub>	-----	-----	50	μA	V <sub>R</sub> =5V

#### Notes:

1. Tolerance of Luminous Flux: ± 7%
2. Tolerance of Forward Voltage: ± 0.05V

## Side View LEDs (Height 0.4 mm)

---

**99-218GLM2C/L5762SG6/TR8-T**

### Bin Range of Luminous Flux

Bin Code	Lm(Min.)	Lm(Max.)	Unit	Condition	Mcd(Min.)	Mcd(Max.)
57	5.75	6.00	Lm	If=20mA	2055	2145
60	6.00	6.25			2145	2235
62	6.25	6.50			2235	2325

**Note:** Tolerance of Luminous Intensity、Luminous Flux:  $\pm 7\%$

## Side View LEDs (Height 0.4 mm)

**99-218GLM2C/L5762SG6/TR8-T**

### Bin Range of Forward Voltage

Bin Code	Min.	Max.	Unit	Condition
6-1	2.95	3.05	V	I <sub>F</sub> =20mA
6-2	3.05	3.15		
7-1	3.15	3.25		
7-2	3.25	3.35		
8-1	3.35	3.45		

**Note:** Tolerance of Forward Voltage:  $\pm 0.05V$

## Side View LEDs (Height 0.4 mm)

### 99-218GLM2C/L5762SG6/TR8-T

#### Chromaticity Coordinates of Bin Code

Bin Code	CIE_x	CIE_y	Bin Code	CIE_x	CIE_y
NA0-4-1	0.2850	0.2670	NA0-4-2	0.2893	0.2743
	0.2820	0.2720		0.2865	0.2795
	0.2865	0.2795		0.2910	0.2870
	0.2893	0.2743		0.2935	0.2815
NA0-4-3	0.2880	0.2620	NA0-4-4	0.2920	0.2690
	0.2850	0.2670		0.2893	0.2743
	0.2893	0.2743		0.2935	0.2815
	0.2920	0.2690		0.2960	0.2760
NB5-3-1	0.2935	0.2815	NB5-3-2	0.2975	0.2885
	0.2910	0.2870		0.2950	0.2940
	0.2950	0.2940		0.2990	0.3010
	0.2975	0.2885		0.3015	0.2955
NB5-3-3	0.2960	0.2760	NB5-3-4	0.3000	0.2830
	0.2935	0.2815		0.2975	0.2885
	0.2975	0.2885		0.3015	0.2955
	0.3000	0.2830		0.3040	0.2900

**Note:** Tolerance of Chromaticity Coordinates:  $\pm 0.01$

Side View LEDs (Height 0.4 mm)

99-218GLM2C/L5762SG6/TR8-T

Chromaticity Coordinates of Bin Code

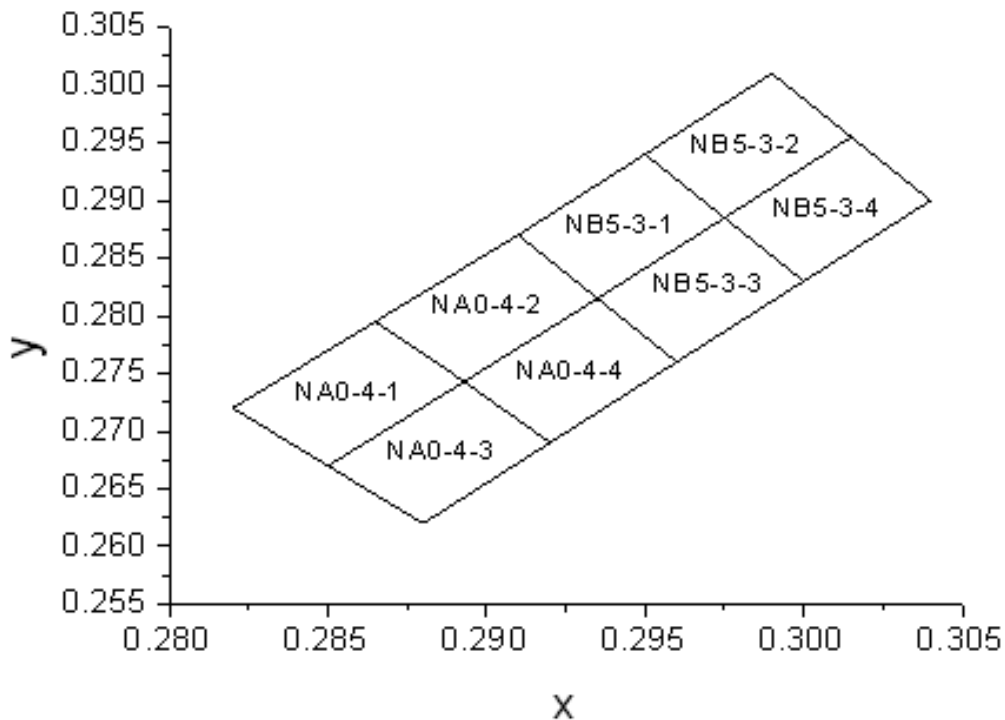

## Side View LEDs (Height 0.4 mm)

### 99-218GLM2C/L5762SG6/TR8-T

#### Typical Electro-Optical-Thermal Characteristics Curves

##### 1. Spectrum Distribution

( $T_s=25^\circ\text{C}$ ,  $I_f=20\text{mA}$ )

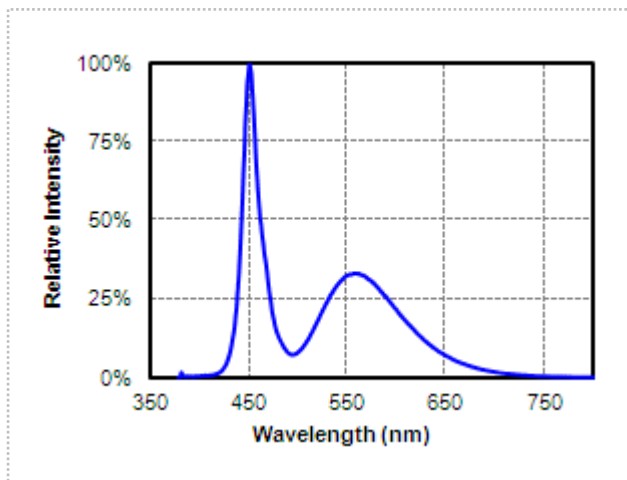

##### 2. Relative Luminous Flux vs. Forward Current

( $T_s=25^\circ\text{C}$ )

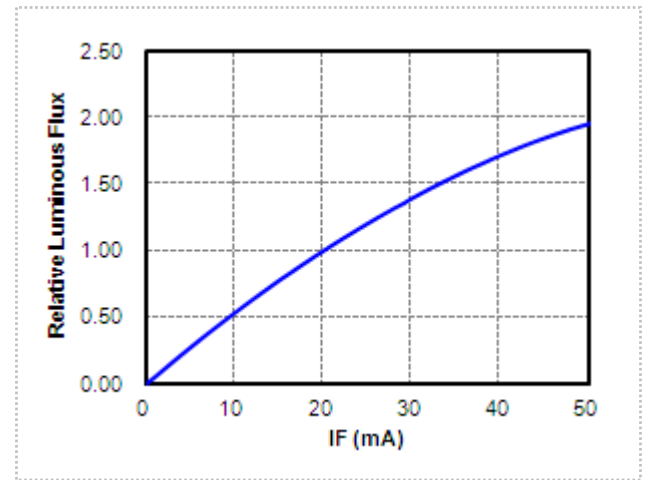

##### 3. Relative Forward Voltage vs. Forward Current

( $T_s=25^\circ\text{C}$ )

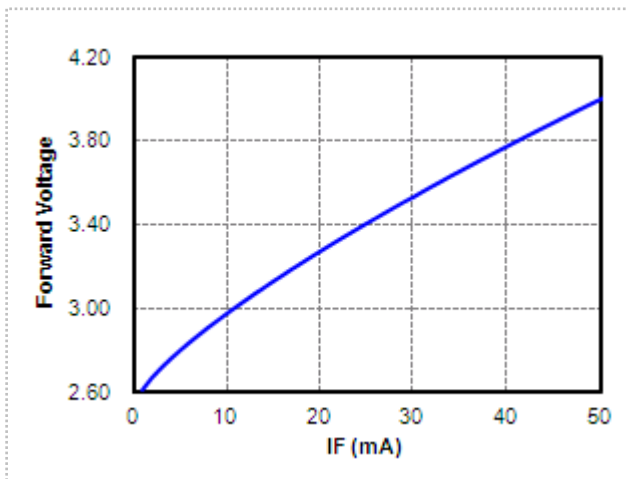

##### 4. Radiation Diagram

( $T_s=25^\circ\text{C}$ ,  $I_f=20\text{mA}$ )

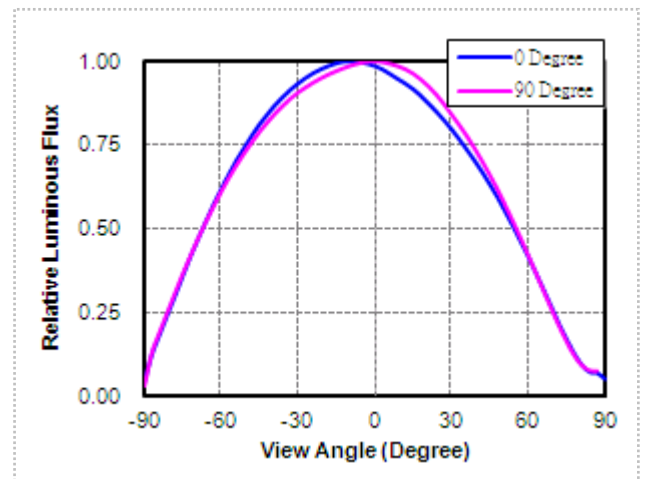



#### Typical Electro-Optical-Thermal Characteristics Curves

5. Relative Luminous Flux vs. Ambient Temperature  
( $I_F=20\text{mA}$ )

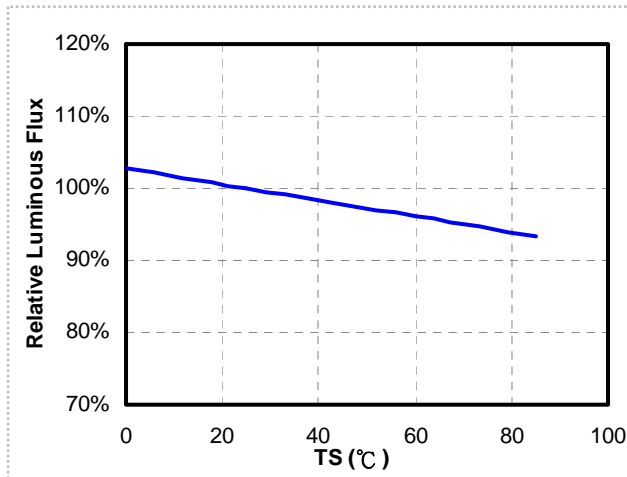

6. Forward Voltage vs. Ambient Temperature  
( $I_F=20\text{mA}$ )

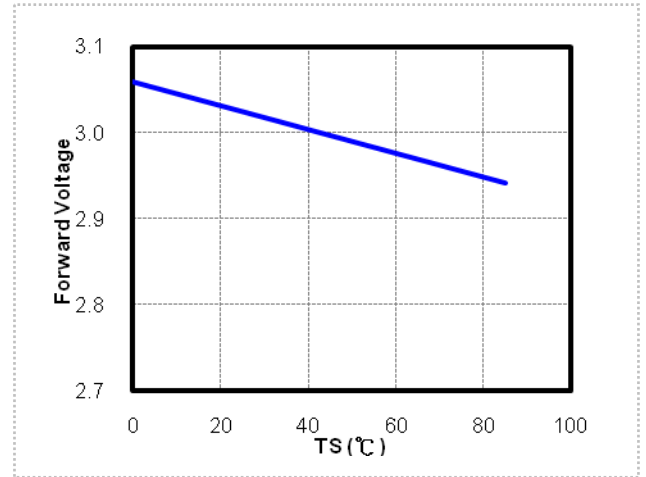

7. Chromaticity Coordinates vs. Ambient Temperature  
( $I_F=20\text{mA}$ )

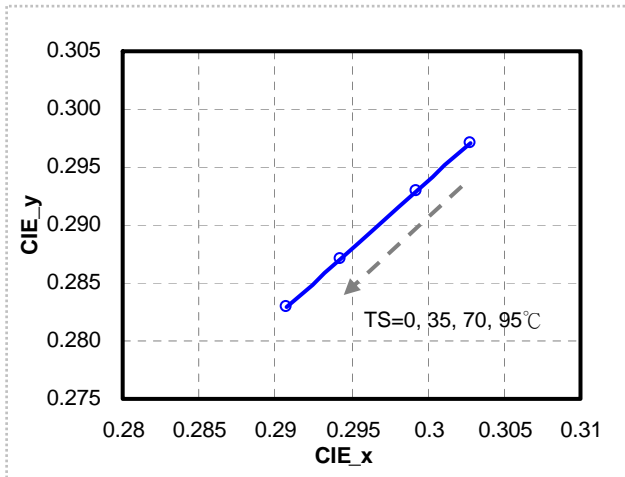

8. Forward Current De-rating Curve

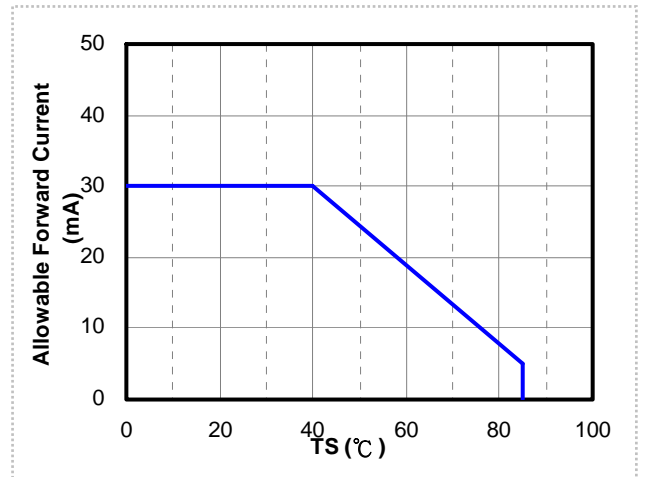

# Technical Data Sheet



## Side View LEDs (Height 0.4 mm)

### 99-218GLM2C/L5762SG6/TR8-T

#### Label Explanation

CAT: Luminous Flux Rank

HUE: Chromaticity Coordinates

REF: Forward Voltage Rank



#### Reel Dimensions

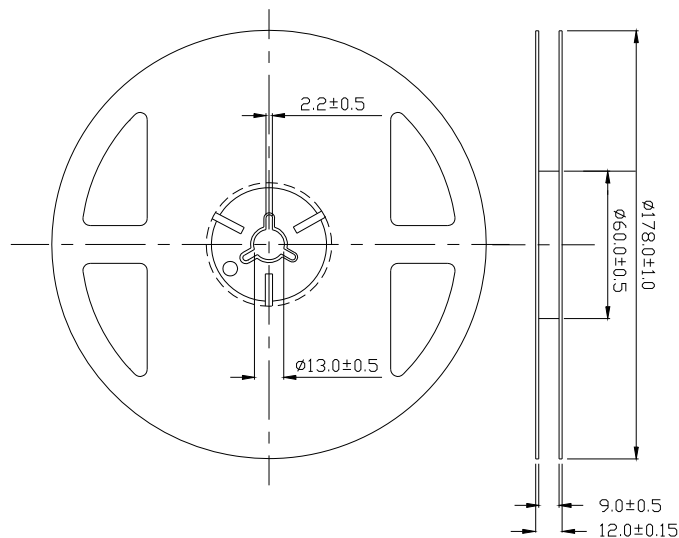

**Note:** The tolerances unless dimension are  $\pm 0.1$ mm.

**Side View LEDs (Height 0.4 mm)**

**99-218GLM2C/L5762SG6/TR8-T**

**Carrier Tape Dimensions: Loaded Quantity 250 up/500/1000/2000 pcs. Per Reel**

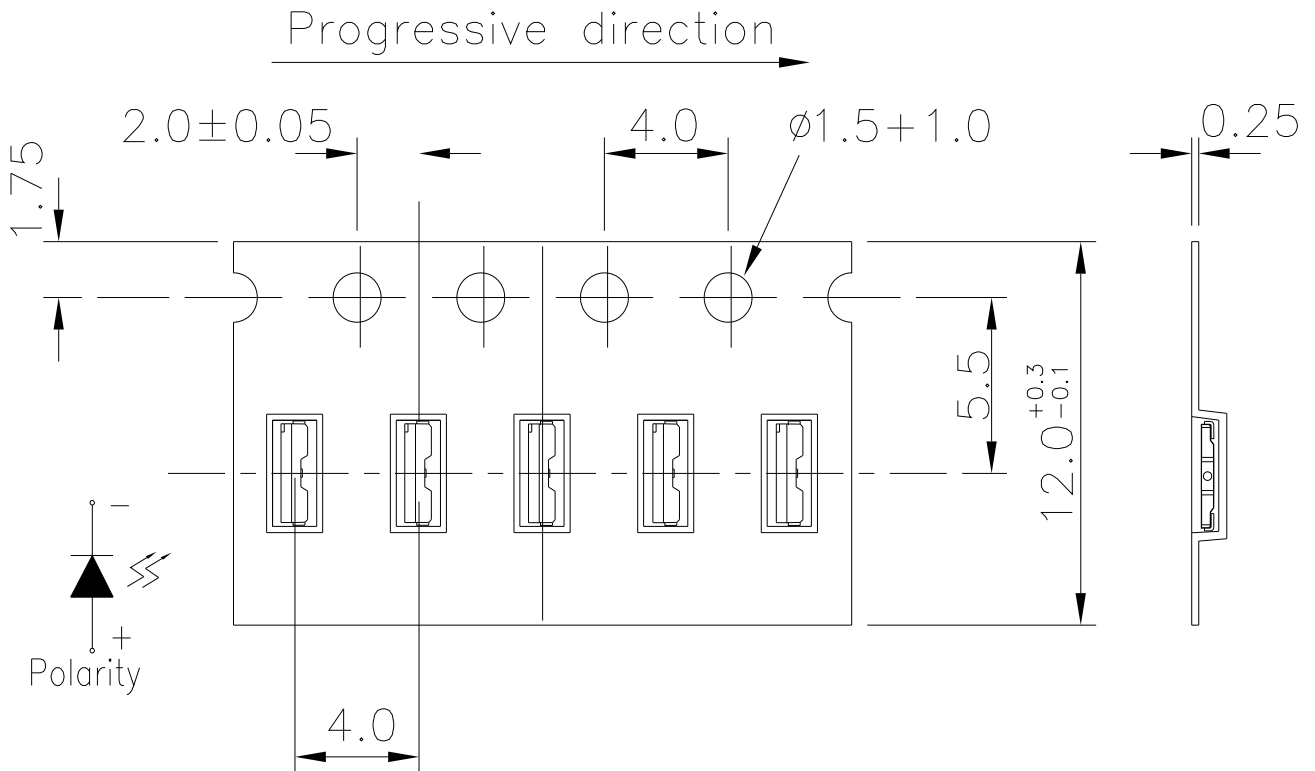

**Note:** The tolerances unless mentioned is ±0.1mm, Unit = mm.

**Moisture Resistant Packaging**

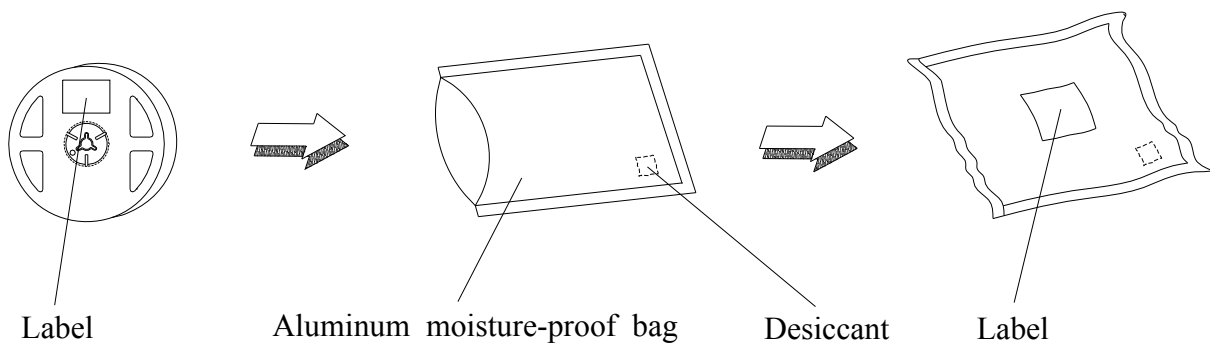

**Note:** Actual photo of standard packing bag

## Side View LEDs (Height 0.4 mm)

### 99-218GLM2C/L5762SG6/TR8-T

#### Reliability Test Items and Conditions

The reliability of products shall be satisfied with items listed below.

Confidence level : 90%

LTPD : 10%

NO	Item	Test Condition		Test Hours / Times	Criteria	
		Temp./ Humidity	IF (mA)		I <sub>v</sub> @20mA	V <sub>F</sub> @20mA
1	Reflow Soldering	TSld = 260°C, Max. 10sec.		2 time	<±10%	<±10%
2	Thermal Cycle	-40°C 30min.	~ (5min.)	100°C 30min.	200 cycles	I <sub>v</sub> > 70%, V <sub>F</sub> < 110%,
3	Thermal Shock	-10°C 20min.	~ (<15sec.)	100°C 20min.	200 cycles	
4	Low Temp. Storage	Ta= -40°C	--	1000 hrs		
5	High Temp. Storage	Ta= 100°C	--	1000 hrs		
6	Temp. Humidity Storage	Ta= 60°C / 90%RH	--	1000 hrs		
7	Steady State Operating Life of Low Temp.	Ta= -40°C	20	1000 hrs		
8	Steady State Operating Life Condition 1	Ta= 25°C / Room Humidity	20	1000 hrs		
9	Steady State Operating Life Condition 2	Ta= 60°C	20	1000 hrs		
10	Steady State Operating Life of High Temp.	Ta= 85°C	5	1000 hrs		
11	Steady State Operating Life of High Humidity Heat	Ta= 60°C / 90%RH	20	1000 hrs		

## Side View LEDs (Height 0.4 mm)

**99-218GLM2C/L5762SG6/TR8-T**

### Precautions For Use

#### 1. Over-current-proof

Customer must apply resistors for protection, otherwise slight voltage shift will cause big current change ( Burn out will happen ).

#### 2. Soldering Condition

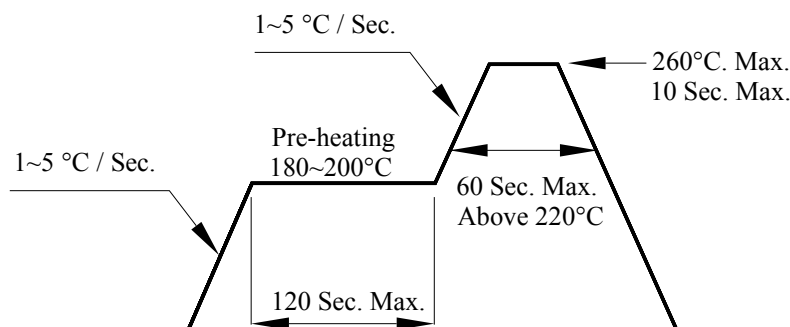

##### 2.1 Pb-free solder temperature profile

2.2 Reflow soldering should not be done more than two times.

2.3 When soldering, do not put stress on the LEDs during heating.

2.4 After soldering, do not warp the circuit board.

#### 3. Soldering Iron

Each terminal is to go to the tip of soldering iron temperature less than 350°C for 3 seconds within once in less than the soldering iron capacity 25W. Leave two seconds and more intervals, and do soldering of each terminal. Be careful because the damage of the product is often started at the time of the hand solder.

#### 4. Repairing

Repair should not be done after the LEDs have been soldered. When repairing is unavoidable, a double-head soldering iron should be used (as below figure). It should be confirmed beforehand whether the characteristics of the LEDs will or will not be damaged by repairing.

## Side View LEDs (Height 0.4 mm)

**99-218GLM2C/L5762SG6/TR8-T**

### 5. Storage

- 5.1 Do not open moisture proof bag before the products are ready to use.
- 5.2 Before opening the package: The LEDs should be used within one year and kept at 30°C or less and 70%RH or less.
- 5.3 After opening the package: We recommend that the LED should be soldered quickly (within 3 days). The soldering condition is 30°C or less and 60%RH or less. If unused LEDs remain, it should be stored in moisture proof.
- 5.4 If the moisture absorbent material (silica gel) has faded away or the LEDs have exceeded the storage time, baking treatment should be performed using the following conditions.  
Baking treatment: 60±5°C for 24 hours. (One time only)

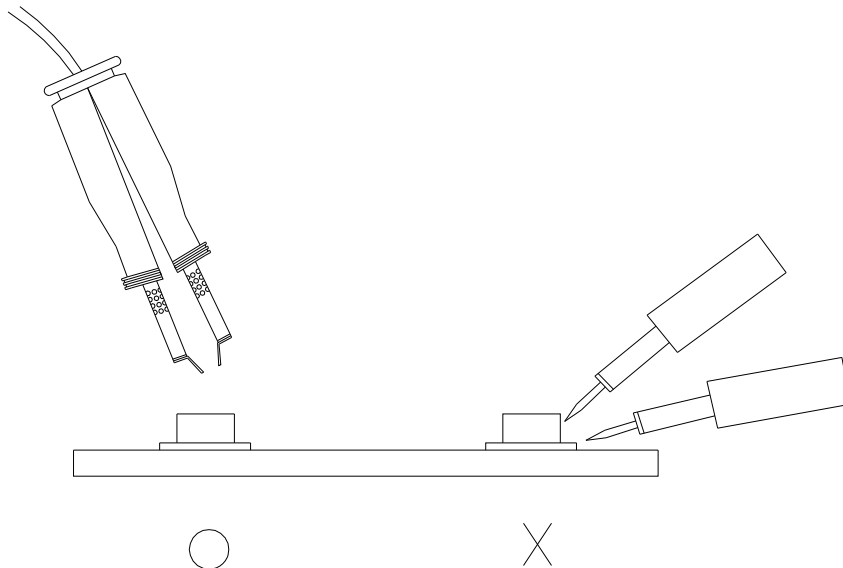

### 6. Handling Indications

During processing, mechanical stress on the surface should be minimized as much as possible. Sharp objects of all types should not be used to pierce the sealing compound

**EVERLIGHT ELECTRONICS CO., LTD.**  
Office: No.6-8, Zhonghua Rd., Shulin Dist  
New Taipei City 236, Taiwan, R.O.C

Tel: 886-2-2685-6688  
Fax: 886- 2685-6880  
<http://www.everlight.com>